

aiwa

COMPACT DISC STEREO SYSTEM
SISTEMA ESTEREO CON REPRODUCTOR DE DISCOS COMPACTOS
CHAINE STEREO AVEC LECTEUR DE DISQUES COMPACTS

NSX-AJ10

OPERATING INSTRUCTIONS
MANUAL DE INSTRUCCIONES
MODE D'EMPLOI

En (English)

E (Español)

F (Français)

Owner's record

For your convenience, record the model number and serial number (you will find them on the rear of your set) in the space provided below. Please refer to them when you contact your Aiwa dealer in case of difficulty.

Model No. _____ Serial No. _____

For assistance and information



call toll free 1-800-BUY-AIWA (United States and Puerto Rico)

COMPACT
disc
DIGITAL AUDIO

U

WARNING

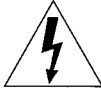
TO REDUCE THE RISK OF FIRE OR ELECTRIC SHOCK, DO NOT EXPOSE THIS APPLIANCE TO RAIN OR MOISTURE.

	CAUTION RISK OF ELECTRIC SHOCK DO NOT OPEN	
<p>“CAUTION: TO REDUCE THE RISK OF ELECTRIC SHOCK, DO NOT REMOVE COVER (OR BACK). NO USER-SERVICEABLE PARTS INSIDE. REFER SERVICING TO QUALIFIED SERVICE PERSONNEL.”</p>		

Explanation of Graphical Symbols:



The lightning flash with arrowhead symbol, within an equilateral triangle, is intended to alert the user to the presence of uninsulated “dangerous voltage” within the product’s enclosure that may be of sufficient magnitude to constitute a risk of electric shock to persons.



The exclamation point within an equilateral triangle is intended to alert the user to the presence of important operating and maintenance (servicing) instructions in the literature accompanying the appliance.

NOTE

This equipment has been tested and found to comply with the limits for a Class B digital device, pursuant to Part 15 of the FCC Rules. These limits are designed to provide reasonable protection against harmful interference in a residential installation.

This equipment generates, uses, and can radiate radio frequency energy and, if not installed and used in accordance with the instructions, may cause harmful interference to radio communications. However, there is no guarantee that interference will not occur in a particular installation. If this equipment does cause harmful interference to radio or television reception, which can be determined by turning the equipment off and on, the user is encouraged to try to correct the interference by one or more of the following measures:

- Reorient or relocate the receiving antenna.
- Increase the separation between the equipment and receiver.
- Connect the equipment into an outlet on circuit different from that to which the receiver is connected.
- Consult the dealer or an experienced radio/TV technician for help.

CAUTION

Modifications or adjustments to this product, which are not expressly approved by the manufacturer, may void the user’s right or authority to operate this product.

PRECAUTIONS

Read the Operating Instructions carefully and completely before operating the unit. Be sure to keep the Operating Instructions for future reference. All warnings and cautions in the Operating Instructions and on the unit should be strictly followed, as well as the safety suggestions below.

Installation

- 1 Water and moisture** — Do not use this unit near water, such as near a bathtub, washbowl, swimming pool, or the like.
- 2 Heat** — Do not use this unit near sources of heat, including heating vents, stoves, or other appliances that generate heat. It also should not be placed in temperatures less than 5°C (41°F) or greater than 35°C (95°F).
- 3 Mounting surface** — Place the unit on a flat, even surface.
- 4 Ventilation** — The unit should be situated with adequate space around it so that proper heat ventilation is assured. Allow 10 cm (4 in.) clearance from the rear and the top of the unit, and 5 cm (2 in.) from each side.
 - Do not place the unit on a bed, rug, or similar surface that may block the ventilation openings.
 - Do not install the unit in a bookcase, cabinet, or airtight rack where ventilation may be impeded.
- 5 Objects and liquid entry** — Take care that objects or liquids do not get inside the unit through the ventilation openings.
- 6 Carts and stands** — When placed or mounted on a stand or cart, the unit should be moved with care. Quick stops, excessive force, and uneven surfaces may cause the unit or cart to overturn or fall.
 
- 7 Condensation** — Moisture may form on the CD pickup lens when:
 - The unit is moved from a cold spot to a warm spot
 - The heating system has just been turned on
 - The unit is used in a very humid room
 - The unit is cooled by an air conditioner
 When this unit has condensation inside, it may not function normally. Should this occur, leave the unit for a few hours, then try to operate again.
- 8 Wall or ceiling mounting** — The unit should not be mounted on a wall or ceiling, unless specified in the Operating Instructions.

Electric Power

- 1 Power sources** — Connect this unit only to power sources specified in the Operating Instructions, and as marked on the unit.
- 2 Polarization** — As a safety feature, some units are equipped with polarized AC power plugs which can only be inserted one way into a power outlet. If it is difficult or impossible to insert the AC power plug into an outlet, turn the plug over and try again. If it still does not easily insert into the outlet, please call a qualified service technician to service or replace the outlet. To avoid defeating the safety feature of the polarized plug, do not force it into a power outlet.
- 3 AC power cord**
 - When disconnecting the AC power cord, pull it out by the AC power plug. Do not pull the cord itself.
 - Never handle the AC power plug with wet hands, as this could result in fire or shock.
 - Power cords should be firmly secured to avoid being severely bent, pinched, or walked upon. Pay particular attention to the cord from the unit to the power outlet.
 - Avoid overloading AC outlets and extension cords beyond their capacity, as this could result in fire or shock.

- 4 **Extension cord** — To help prevent electric shock, do not use a polarized AC power plug with an extension cord, receptacle, or other outlet unless the polarized plug can be completely inserted to prevent exposure of the blades of the plug.
- 5 **When not in use** — Unplug the AC power cord from the power outlet if the unit will not be used for several months or more. When the cord is plugged in, a small amount of current continues to flow to the unit, even when the power is turned off.

Outdoor Antenna

- 1 **Power lines** — When connecting an outdoor antenna, make sure it is located away from power lines.
- 2 **Outdoor antenna grounding** — Be sure the antenna system is properly grounded to provide protection against unexpected voltage surges or static electricity build-up. Article 810 of the National Electrical Code, ANSI/NFPA 70, provides information on proper grounding of the mast, supporting structure, and the lead-in wire to the antenna discharge unit, as well as the size of the grounding unit, connection to grounding terminals, and requirements for grounding terminals themselves.

Antenna Grounding According to the National Electrical Code

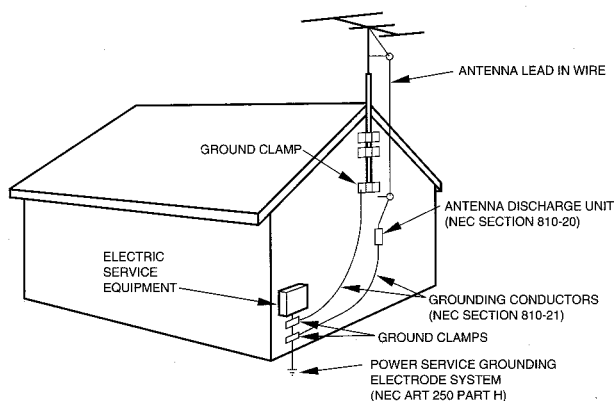

NEC-NATIONAL ELECTRICAL CODE

Maintenance

Clean the unit only as recommended in the Operating Instructions.

Damage Requiring Service

Have the units serviced by a qualified service technician if:

- The AC power cord or plug has been damaged
- Foreign objects or liquid have gotten inside the unit
- The unit has been exposed to rain or water
- The unit does not seem to operate normally
- The unit exhibits a marked change in performance
- The unit has been dropped, or the cabinet has been damaged

DO NOT ATTEMPT TO SERVICE THE UNIT YOURSELF.

TABLE OF CONTENTS

PRECAUTIONS	2
PREPARATIONS	
CONNECTIONS	4
REMOTE CONTROL	5
BEFORE OPERATION	6
SETTING THE CLOCK	7
SOUND	
AUDIO ADJUSTMENTS	7
GRAPHIC EQUALIZER	8
TAPE PLAYBACK	
BASIC OPERATIONS	8
RADIO RECEPTION	
MANUAL TUNING	9
PRESETTING STATIONS	9
CD PLAYING	
BASIC OPERATIONS	10
PROGRAMMED PLAY	11
RECORDING	
BASIC RECORDING	12
AI EDIT RECORDING	13
PROGRAMMED EDIT RECORDING	14
TIMER	
SETTING THE TIMER	15
SETTING THE SLEEP TIMER	16
OTHER FEATURES	
DEMO (Demonstration)	16
OTHER CONNECTIONS	
CONNECTING OPTIONAL EQUIPMENT	17
LISTENING TO EXTERNAL SOURCES	17
GENERAL	
CARE AND MAINTENANCE	18
TROUBLESHOOTING GUIDE	18
SPECIFICATIONS	19
PARTS INDEX	<i>Back cover</i>

En

Check your system and accessories

NSX-AJ10

CX-NAJ10 Compact disc stereo cassette receiver
SX-NAJ12 Front speakers

Remote control

AM antenna

FM antenna

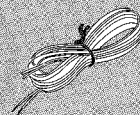

CONNECTIONS

Before connecting the AC cord

The rated voltage of your unit shown on the rear panel is 120 V AC. Check that the rated voltage matches your local voltage.

IMPORTANT

Connect the speakers, antennas, and all optional equipment first. Then connect the AC cord.

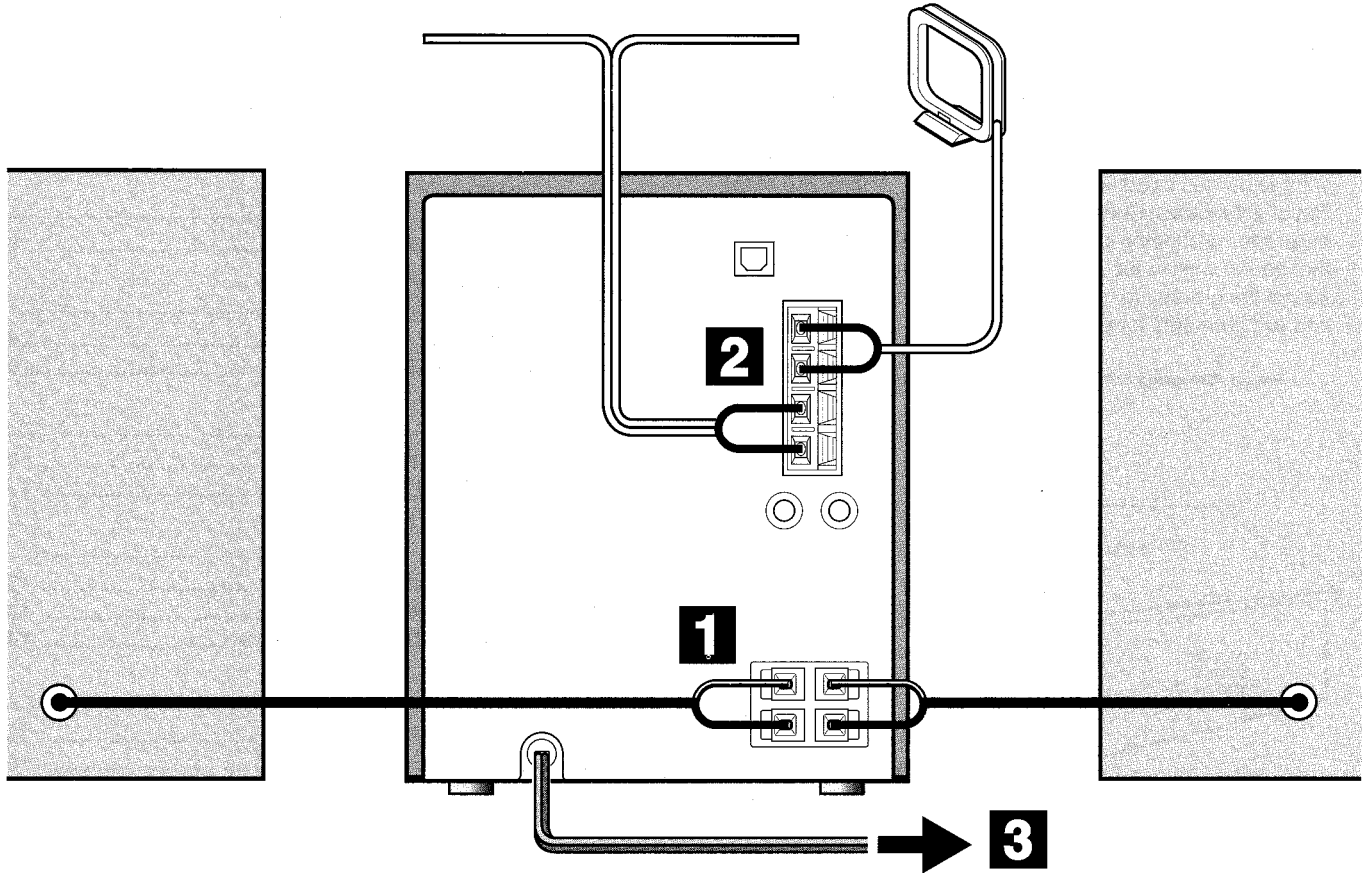

1 Connect the right and left speakers to the main unit.

Connect the right speaker cord to **SPEAKERS R** terminals, and left to **SPEAKERS L** terminals.

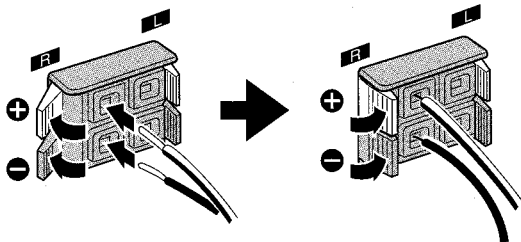

The speaker cord with the white stripe should be connected to **+** terminal and the black cord to **-** terminal.

NOTE

Be sure to connect the speaker cords correctly. Improper connections can cause short circuits in **SPEAKERS** terminals.

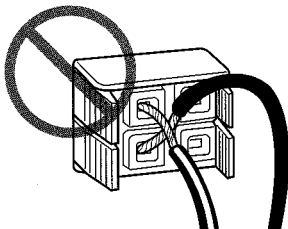

2 Connect the supplied antennas.

Connect the FM antenna to **FM 75 Ω** terminals and the AM antenna to **AM LOOP** terminals.

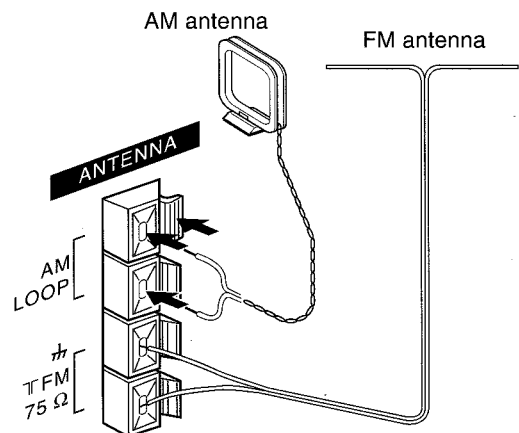

3 Connect the AC cord to an AC outlet.

- The DEMO will begin when the AC cord is plugged into an AC outlet for the first time. To deactivate the DEMO, set the clock.

NOTE

- Do not leave objects generating magnetism, such as credit cards, near the speakers, as these objects may be damaged.
- Do not bring the FM antenna near metal objects or curtain rails.
- Do not bring the AM antenna near other optional equipment, the stereo system itself, the AC cord or speaker cords, since noise will be picked up.
- Do not unwind the AM antenna wire.

To position the antennas

FM antenna:

Extend this antenna horizontally in a T-shape and fix its ends to the wall.

AM antenna:

Position and rotate this antenna to find the best possible reception.

To stand the AM antenna on a surface

Fix the claw to the slot.

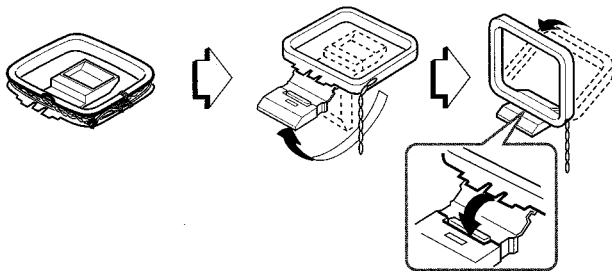

CONNECTING AN OUTDOOR ANTENNA

For better FM reception, use of an outdoor antenna is recommended.

Connect the outdoor antenna to **FM 75 Ω** terminals.

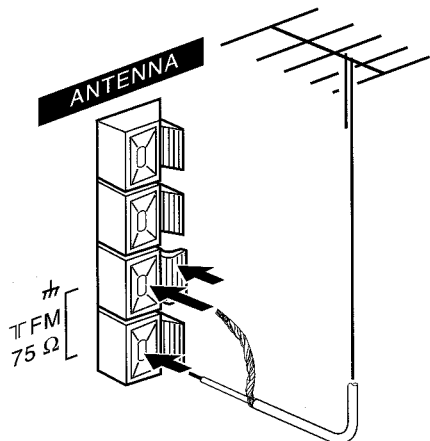

To connect other optional equipment → page 17.

REMOTE CONTROL

Inserting batteries

Detach the battery cover on the rear of the remote control and insert two R6 (size AA) batteries.

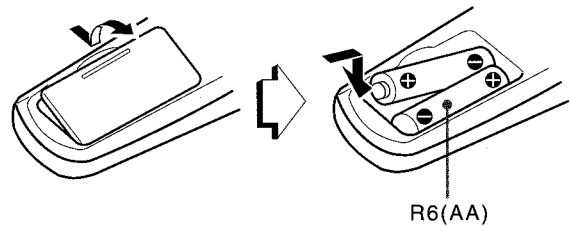

When to replace the batteries

The maximum operational distance between the remote control and the sensor on the main unit should be approximately 5 meters (16 feet). When this distance decreases, replace the batteries with new ones.

To use SHIFT on the remote control

Buttons ① have two different functions. One of these functions is indicated on the button, and the other on the plate above the button.

To use the function on the button, simply press the button.

To use the function on the plate above the button, press the button while pressing **SHIFT**.

To use FUNCTION on the remote control

FUNCTION substitutes for the function buttons (**TAPE, TUNER/BAND, VIDEO/AUX, CD**) on the main unit.

Each time **FUNCTION** is pressed, the next function is selected cyclically.

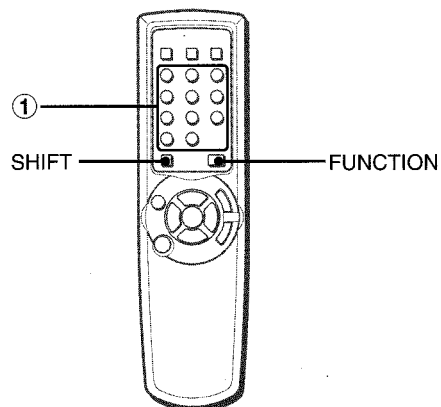

NOTE

- If the remote control is not going to be used for an extended period of time, remove the batteries to prevent possible electrolyte leakage.
- The remote control may not operate correctly when:
 - The line of sight between the remote control and the remote sensor inside the display window is exposed to intense light, such as direct sunlight
 - Other remote controls are used nearby (those of a television, etc.)

BEFORE OPERATION

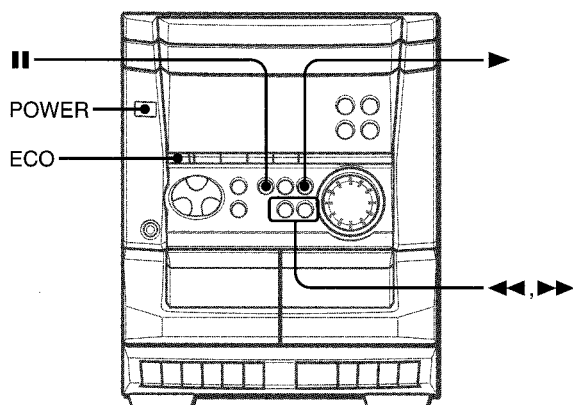

To turn the power on

Press one of the function buttons (**TAPE**, **TUNER**, **VIDEO/AUX**, **CD**). Playback of the inserted disc begins, or the previously tuned station is received (Direct Play Function).

POWER is also available.

To turn the power off

Press **POWER**.

NOTE

When the power is turned on, the disc compartment may open and close to reset the unit.

DEMO (Demonstration)

When the AC cord is plugged into an AC outlet for the first time after purchase, the DEMO will begin in the display. When the power is turned on, the DEMO will end. When the power is turned off, the DEMO will begin again.

When the clock is set, the DEMO will not begin even if the power is turned off.

To deactivate or activate DEMO

Press **||**, and clock is displayed in place of the DEMO.

Press **▶** to activate.

(For more about the DEMO, see page 16)

SETTING POWER ECONOMIZING MODE

When you set power economizing mode to "ECO ON" or "ECO AUTO", the unit reduces power consumption by conducting four ECO operations as follows.

ECO ON

- The unit (all the illumination of the display) blacks out when the power is turned off. Only the red indicator lights up.
- If DIMMER (1-3) is selected, the illumination of the display brighten for 10 seconds only when you press a button (on deck 1 and 2, only **●** and **▶**) or turn **VOLUME**.
- The display dimmer mode is set to the dimmest and the volume is set to the minimum (0) when the unit turns on by timer recording.

ECO AUTO

- In addition to the three operations of ECO ON, the unit automatically turns itself off if you do not operate it and the function is in stop mode for 10 minutes when CD or TAPE is selected.

ECO OFF

- The power economizing mode does not function.

1 Press ECO.

"ECO MODE" will be displayed.

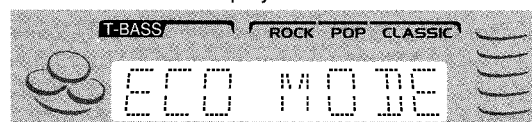

2 Press **||** within 4 seconds.

The current power-economizing mode status will be displayed.

3 Press **◀** or **▶** within 4 seconds to select one of the power-economizing mode.

Example: When "ON" is selected

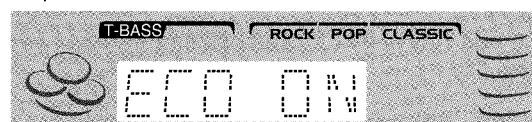

4 Press **||** within 4 seconds.

NOTE

If the clock is not set, the unit does not black out. Instead, the DEMO will begin when the power is turned off.

DIMMER MODE

To change the display dimmer mode

- 1 Press **ECO** repeatedly until "DIM MODE" is displayed.
- 2 Within 4 seconds, press **||**.
- 3 Within 4 seconds, press **◀** or **▶** to select one of the dimmer modes changed cyclically as below.
- 4 Within 4 seconds, press **||**.

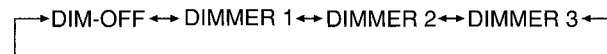

"DIM-OFF" mode is the brightest and "DIMMER 3" mode is the dimmest.

SETTING THE CLOCK

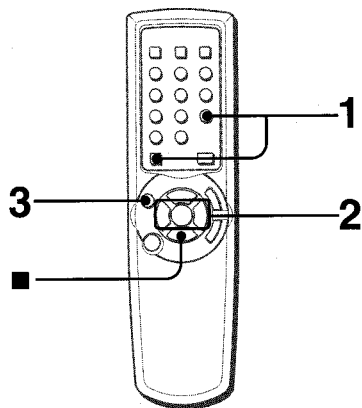

Use the remote control.

1 Press **CLOCK** while pressing **SHIFT**.

When using the unit, press **II** while the power is off.
The clock is displayed. (The ":" between the hours and minutes flashes.)

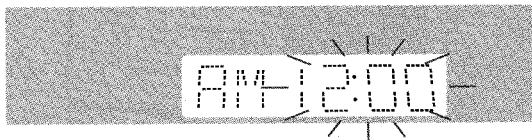

2 Within 4 seconds, press **◀◀** or **▶▶** to designate the hour and the minute.

Pressing either button changes both the hour and the minute. Holding it down will vary the time rapidly by 10-minute interval, and pressing it repeatedly will vary by 1 minute interval.

3 Press **II**.

The clock starts from 00 seconds.

To restore an original clock setting

Press **CLOCK** while pressing **SHIFT** before completing step 3 to restore the previous time setting. This cancels any new setting.

To view the clock when another display is in the display

Press **CLOCK** while pressing **SHIFT**. The time is displayed for 4 seconds and then the original display reappears. However, the clock cannot be displayed during recording.

To switch to the 24-hour standard

Press **CLOCK** while pressing **SHIFT** and then press **■** within 4 seconds.

Repeat the same procedure to restore the 12-hour standard.

In the 12-hour standard, "AM 12:00" indicates midnight and "PM12:00" indicates noon.

If the clock display flashes

If the display flashes when the clock is displayed, it indicates that the clock has stopped due to a power failure or the removal of the power cord. The current time needs to be reset.

NOTE

If the power-economizing mode (page 6) is on, the unit blacks out when the power is turned off. To view the clock, press **CLOCK** while pressing **SHIFT** so that the time is displayed for 4 seconds.

AUDIO ADJUSTMENTS

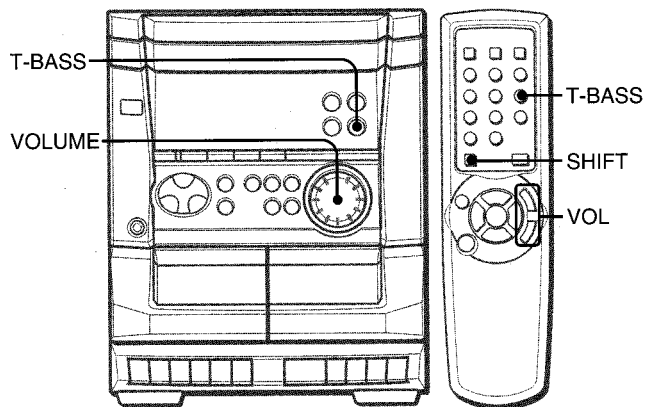

VOLUME

Turn **VOLUME** on the main unit, or press **VOL** on the remote control.

The volume level is displayed as a number from 0 to MAX (31). The volume level is automatically set to 16 when the power is turned off with the volume level set to 17 or more.

SUPER T-BASS SYSTEM

The T-BASS system enhances the realism of low-frequency sound.

Press T-BASS.

Each time it is pressed, the level changes. Select one of the three levels, or the off position to suit your preference.

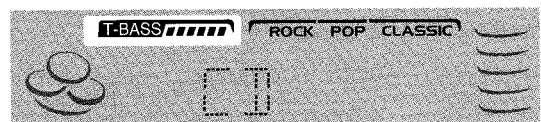

To select with the remote control

Press **T-BASS** while pressing **SHIFT**.

NOTE

Low frequency sound may be distorted when the T-BASS system is used for a disc or tape in which low frequency sound is originally emphasized. In this case, cancel the T-BASS system.

GRAPHIC EQUALIZER

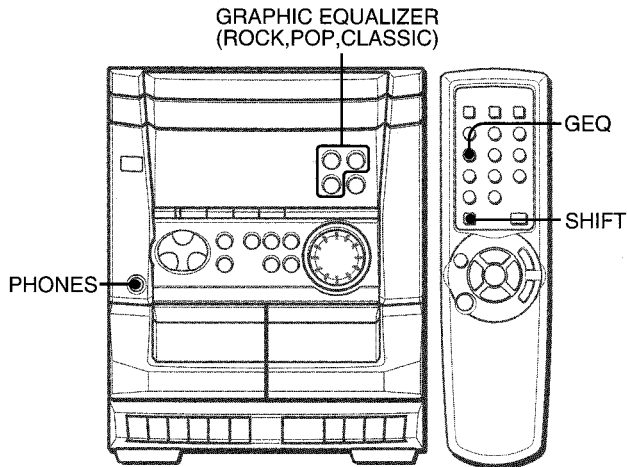

This unit provides the following three different equalization curves.
ROCK: Powerful sound emphasizing treble and bass
POP: More presence in the vocals and midrange
CLASSIC: Enriched sound with heavy bass and fine treble.

Press one of ROCK, POP or CLASSIC.
 The selected equalization mode is displayed.

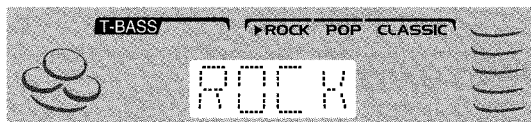

To cancel the selected mode
 Press the selected button again. "GEQ OFF" is displayed.

To select with the remote control
 Press **GEQ** repeatedly while pressing **SHIFT**. The GEQ mode is displayed cyclically as follows.

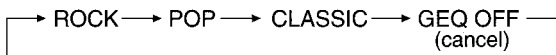

BASIC OPERATIONS

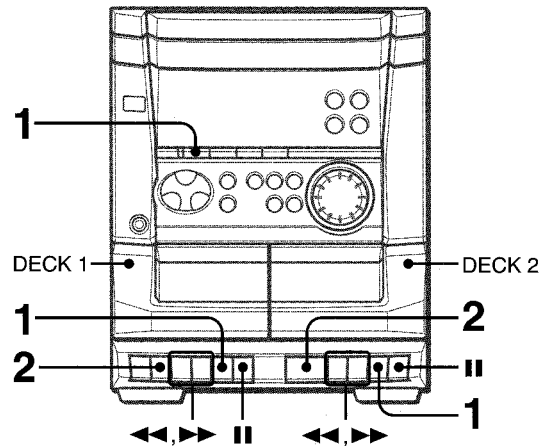

Use type I (normal) tapes only.

1 Press TAPE and press ■/▲ to open the cassette holder.

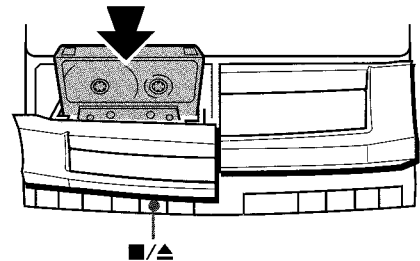

Insert a tape with the exposed side down. Push the cassette holder to close.

2 Press ► to start play.
 Only the side facing out from the unit can be played back.

To stop play, press ■/▲.
To pause play, press ||. To resume play, press again.
To fast forward or rewind, press ◀◀ or ▶▶. Then press ■/▲ to stop the tape.

When both deck 1 and deck 2 are set in the playback mode
 Sound from deck 2 is heard.

Using the headphones
 Connect headphones to the **PHONES** jack with a standard stereo plug (ø6.3 mm, 1/4 inch).
 No sound is output from the speakers while the headphones are plugged in.

Sound adjustment during recording
 The output volume and tone of the speakers or headphones are freely varied without affecting the recording.

MANUAL TUNING

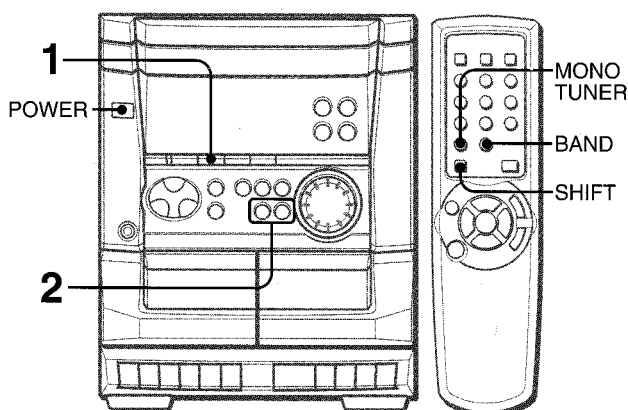

1 Press **TUNER/BAND** repeatedly to select the desired band.



When **TUNER/BAND** is pressed while the power is off, the power is turned on directly.

To select a band with the remote control
Press **BAND** while pressing **SHIFT**.

2 Press **◀ DOWN** or **▶ UP** to select a station.
Each time the button is pressed, the frequency changes.
When a station is received, "TUNE" is displayed for 2 seconds.
During FM stereo reception, ((Ⓜ)) is displayed.

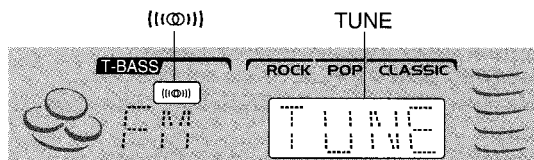

To search for a station quickly (Auto Search)
Keep **◀ DOWN** or **▶ UP** pressed until the frequency starts to change rapidly. After tuning in to a station, the search stops.
To stop the Auto Search manually, press **◀ DOWN** or **▶ UP**.
• The Auto Search may not stop at stations with very weak signals.

When an FM stereo broadcast contains noise
Press **MONO TUNER** while pressing **SHIFT** on the remote control so that "MONO" appears on the display.
Noise is reduced, although reception is monaural.
To restore stereo reception, repeat the above so that "MONO" disappears.

To change the AM tuning interval
The default setting of the AM tuning interval is 10 kHz/step. If you use this unit in an area where the frequency allocation system is 9 kHz/step, change the tuning interval.
Press **POWER** while pressing **TUNER/BAND**.
To reset the interval, repeat this procedure.

NOTE
When the AM tuning interval is changed, all preset stations are cleared. The preset stations have to be set again.

PRESETTING STATIONS

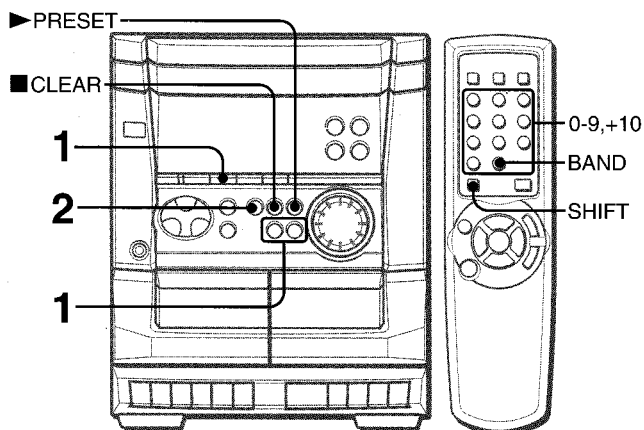

The unit can store a total of 32 preset stations. When a station is stored, a preset number is assigned to the station. Use the preset number to tune in to a preset station directly.

1 Press **TUNER/BAND** to select a band, and press **◀ DOWN** or **▶ UP** to select a station.
2 Press **|| SET** to store the station.
A preset number beginning from 1 in consecutive order for each band is assigned to the station.

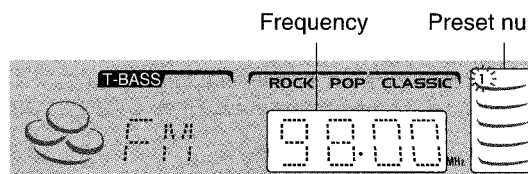

3 Repeat steps 1 and 2.
The next station will not be stored if a total of 32 preset stations for all the bands have already been stored.

NOTE
"FULL" is displayed if you attempt to store more than 32 preset stations.

PRESET NUMBER TUNING

Use the remote control to select the preset number directly.

1 Press **BAND** while pressing **SHIFT** to select a band.
2 Press numbered buttons 0-9 and +10 to select a preset number.
Example:
To select preset number 20, press **+10**, **+10** and **0**.
To select preset number 15, press **+10** and **5**.

Selecting a preset number on the main unit
Press **TUNER/BAND** to select a band. Then, press **▶ PRESET** repeatedly.
Each time **▶ PRESET** is pressed, the next ascending number is selected.

To clear a preset station
Select the preset number of the station to be cleared. Then, press **■ CLEAR**, and press **|| SET** within 4 seconds.
The preset numbers of all other stations in the band with higher numbers are also decreased by one.

BASIC OPERATIONS

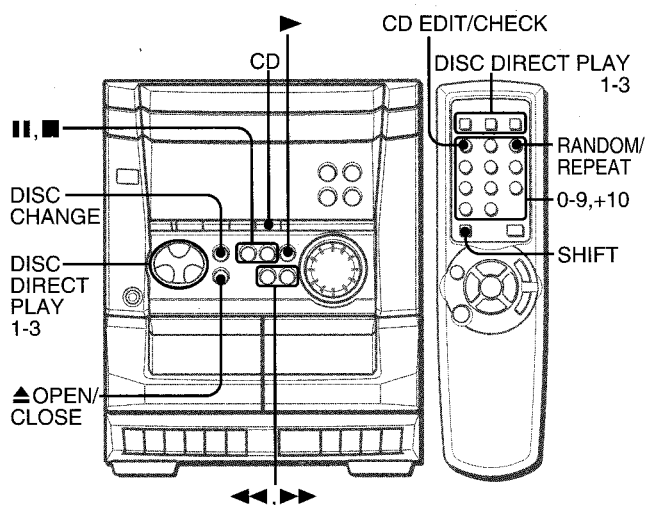

LOADING DISCS

Press **CD**, then press **▲ OPEN/CLOSE** to open the disc compartment. Load disc(s) with the label side up.

To play one or two discs, place the discs on tray 1 and 2.

To play three discs, press **DISC CHANGE** to rotate the trays after placing two discs. Place the third disc on tray 3.

Close the disc compartment by pressing **▲ OPEN/CLOSE**.

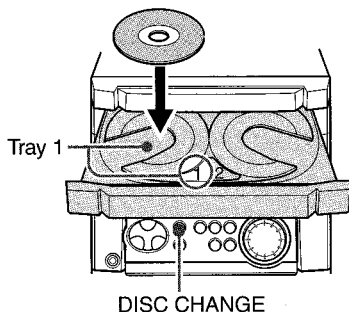

Tray number of the disc to be played

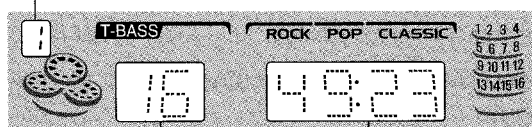

Total number of tracks

Total playing time

PLAYING DISCS

Load discs.

To play all discs in the disc compartment, press ►.

Play begins with the disc on tray 1.

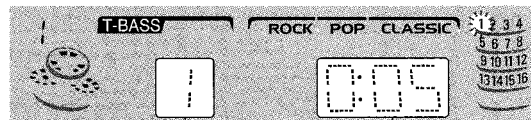

Number of track being played

Elapsed playing time

To play one disc only, press DISC DIRECT PLAY 1-3.

The selected disc is played once.

To stop play, press ■.

To pause play, press ||. To resume play, press again.

To search for a particular point during playback, keep ◀◀ or ▶▶ pressed and release it at the desired point.

To skip to the beginning of a track during playback, press ◀◀ or ▶▶ repeatedly.

To remove discs, press ▲ OPEN/CLOSE.

To start play when the power is off (Direct Play Function)

Press **CD**. The power is turned on and play of the loaded disc(s) begins.

When **▲ OPEN/CLOSE** is pressed, the power is also turned on and the disc compartment is opened.

To check the remaining time

During play (except random play or programmed play), press

CD EDIT/CHECK while pressing **SHIFT** on the remote control.

The amount of time remaining until all tracks finish playing is displayed. To restore the playing time display, repeat the above.

Selecting a track with the remote control

1 Press **DISC DIRECT PLAY 1-3** to select a disc.

2 Press numbered buttons **0-9** and **+10** to select a track.

Example:

To select the 25th track, press **+10, +10** and **5**.

To select the 10th track, press **+10** and **0**.

The selected track starts to play and continues to the end of that disc.

Replacing discs during play

While one disc is playing, the other discs can be replaced without interrupting play.

1 Press **DISC CHANGE**.

2 Remove the discs and replace with other discs.

3 Press **▲ OPEN/CLOSE** to close the disc compartment.

NOTE

- When loading an 8-cm (3-inch) disc, put it onto the inner circle of the tray.
- Do not place more than one compact disc on one disc tray.
- Do not tilt the unit with discs loaded. Doing so may cause malfunctions.
- Do not use irregular shape CDs (example: heart-shaped, octagonal ones). It may result in malfunctions.

RANDOM /REPEAT PLAY

Use the remote control.

RANDOM play

All the tracks on the selected disc or all the discs can be played randomly.

REPEAT play

A single disc or all the discs can be played repeatedly.

Press RANDOM/REPEAT while pressing SHIFT .

Each time it is pressed, the function can be selected cyclically.

RANDOM play — RANDOM lights up on the display.

REPEAT play —  lights up on the display.

RANDOM/REPEAT play — RANDOM and  light up on the display.

Cancel — RANDOM and  disappear from the display.

To play all discs, press  to start play.

To play a single disc, press one of **DISC DIRECT PLAY 1-3** to start play.

NOTE

During random play it is not possible to skip to the previously played track with .

PROGRAMMED PLAY

Up to 30 tracks can be programmed from any of the inserted discs.

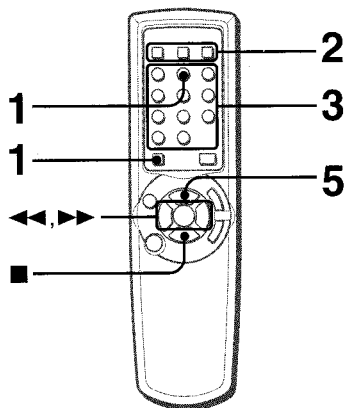

Use the remote control.

1 Press PRGM while pressing SHIFT in stop mode.

"PRGM" is displayed .

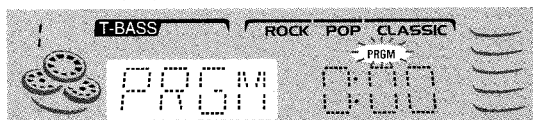

2 Press DISC DIRECT PLAY 1-3 to select a disc.

Go to the next step when the tray stops rotating.

3 Press numbered buttons 0-9 and +10 to program a track.

Example:

To select the 25th track, press +10, +10 and 5.

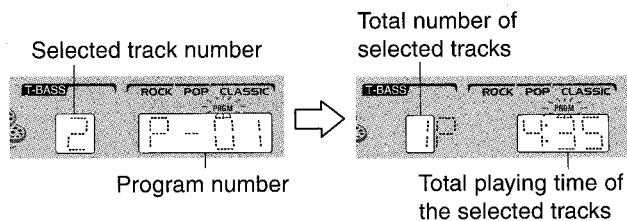

To select the 10th track, press +10 and 0.



4 Repeat steps 2 and 3 to program other tracks.

5 Press to start play.

To check the program

Each time  or  is pressed in stop mode, a disc number, track number, and program number will be displayed.

To clear the program

Press  **CLEAR** in stop mode.

To add tracks to the program

Repeat steps 2 and 3 in stop mode. The track will be programmed after the last track.

To change the programmed tracks

Clear the program and repeat all the steps again.

To play the programmed tracks repeatedly

After programming the tracks, press **RANDOM/REPEAT** repeatedly while pressing **SHIFT** until  appears on the display.

NOTE

- During programmed play, you cannot perform random play, check the remaining time, and select a disc or track. "CAN'T USE" is displayed if you attempt to select a track.
- "FULL" is displayed if you attempt to program more than 30 tracks.

BASIC RECORDING

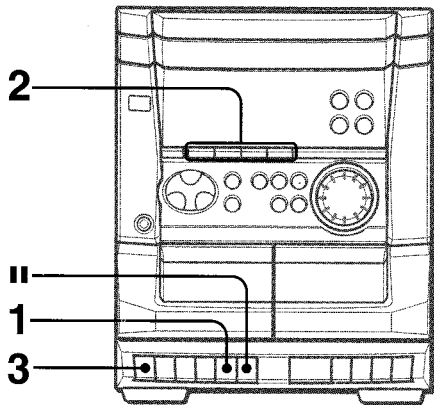

Preparation

- Use Type I (normal) tapes only.
- Set the tape to the point where recording will start.

1 Insert the tape to be recorded on into deck 1.

Press **■/▲** to open the cassette holder and insert the tape with the side to be recorded on first facing out from the unit.

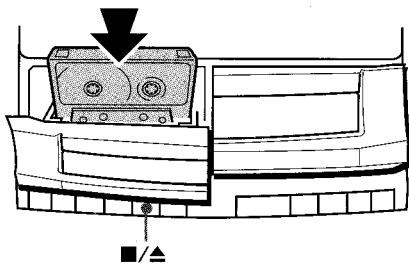

2 Press function (CD, TAPE, TUNER or VIDEO/AUX) and prepare the source to be recorded.

- To record from a CD**, press **CD** and load the disc(s).
- To record from a tape**, press **TAPE**. Then insert the original tape into deck 2 and play it.
- To record from a radio broadcast**, press **TUNER/BAND** and tune in to a station.
- To record from a connected source**, press **VIDEO/AUX**.

3 Press ● to start recording.

▶ is depressed simultaneously. When recording from a connected source, start playback of the source.

When the selected function is CD, playback and recording start simultaneously.

To stop recording, press **■/▲** on deck 1.
To pause recording, press **||** on deck 1. To resume recording, press it again.

To record selected tracks of the CD
 Before pressing ●, program the tracks (see page 11).

To start recording precisely (except when recording from a CD)
 Before pressing ● at step 3 above, press **||** on deck 1. Then, press ●. The deck enters recording pause mode. To restart recording, press **||** again.

To record part of the CD
 When ● is pressed, recording always starts from the first track. To start in the middle of a track, play the CD first and press **||** for CD at the point to start recording from. Then, press ●. The pause mode for CD is released automatically and recording starts.

About cassette tapes

- **To prevent accidental erasure**, break off the plastic tabs on the cassette tape after recording with a screwdriver or other pointed tool.

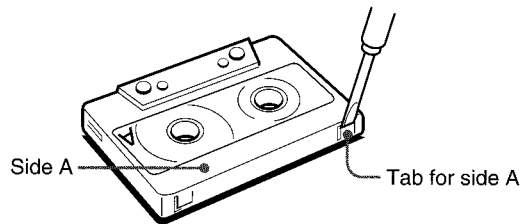

To record on the tape again, cover the tab openings with adhesive tape, etc.

- **120-minute or longer tapes** are extremely thin and easily deformed or damaged. They are not recommended.
- **Take up any slack** in the tape with a pencil or similar tool before use. Slack tape may break or jam in the mechanism.

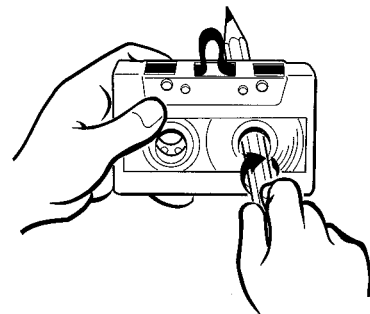

NOTE

Do not press the buttons on deck 2 during recording.

Sound adjustment during recording

The output volume and tone of the speakers or headphones are freely varied without affecting of the recording.

To erase a recording

- 1 Insert the tape to be erased into deck 1 and press **TAPE**.
- 2 Set the tape to the point where the erasure is to be started.
- 3 Press ● to start the erasure.

AI EDIT RECORDING

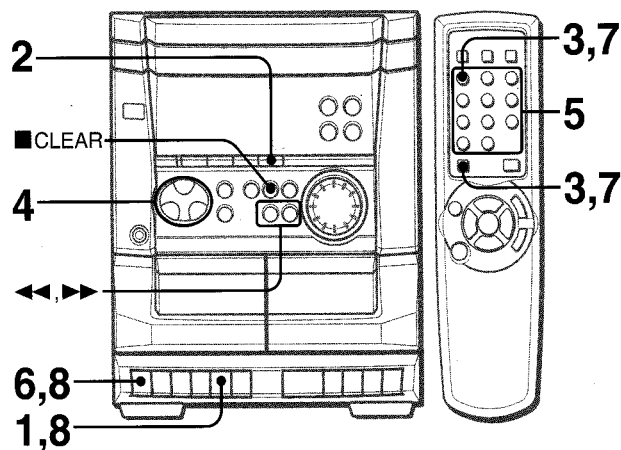

The AI edit recording function enables CD recording without worrying about tape length and track length. When a CD is inserted, the unit automatically calculates the total track length. If necessary, the order of tracks is rearranged so that no track is cut short.

(AI: Artificial Intelligence)

1 Insert the tape into deck 1, and wind up to the beginning of the front side.

Press **■/▲** to open the cassette holder and insert the tape with the side to be recorded on first facing out from the unit. Wind up the tape with **◀◀**.

2 Press CD and load the disc(s).

3 Press CD EDIT/CHECK once while pressing SHIFT on the remote control.

"EDIT" and "AI" are displayed.

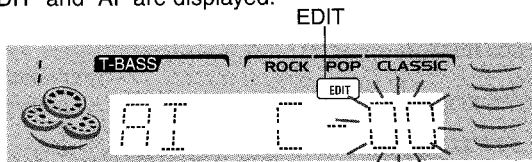

- When "PRGM" is displayed, press **CD EDIT/CHECK** while pressing **SHIFT** again.

4 Press DISC DIRECT PLAY 1-3 to select a disc.

5 Press numbered buttons 0-9 on the remote control to designate the tape length.

10 to 99 minutes can be specified.

Example: When using a 60-minute tape, press **6** and **0**.

In a few seconds, the tracks to be recorded on each side of the tape are determined.

- **◀◀** and **▶▶** are also available to designate the tape length.

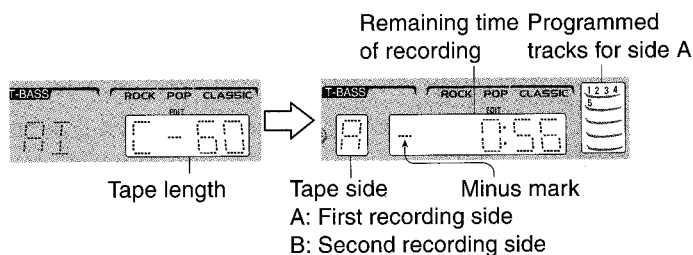

6 Press **●** on deck 1 to start recording on the first side.

CD play and recording of edited tracks for the first side start simultaneously. When the end of the tape is reached, deck 1 enters the recording stop mode. After entering the recording stop mode, go to step 7.

7 Press CD EDIT/CHECK while pressing SHIFT on the remote control to display the program for the second recording.

"B" is displayed.

8 Turn over the tape in deck 1 and press **●** to start recording on the second side.

To stop recording

Press **■/▲** on deck 1. Recording and CD play stop simultaneously.

To clear the edit program

Press **■ CLEAR** twice so that "EDIT" disappears on the display.

To check the order of the programmed track numbers

Before recording, press **CD EDIT/CHECK** while pressing **SHIFT** on the remote control to select side A or B, and press **◀◀** or **▶▶** repeatedly.

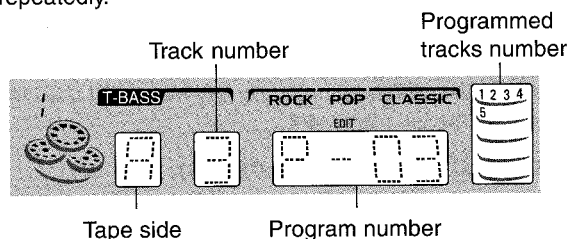

To add tracks from other discs to the edit program

If there is any time remaining on the tape after step 5, you can add tracks from other discs in the CD compartment.

- 1 Press **CD EDIT/CHECK** while pressing **SHIFT** on the remote control to select side A or B.
- 2 Press **DISC DIRECT PLAY 1-3** to select a disc.
- 3 Press numbered buttons on the remote control to select tracks. A track whose playing time is longer than the remaining time cannot be programmed.
- 4 Repeat steps 2 and 3 to add more tracks.

Time on cassette tapes and editing time

The actual cassette recording time is usually a little longer than the specified recording time printed on the label. This unit can program tracks to use the extra time. When the total recording time is a little longer than the tape's specified recording time after editing, the display shows the extra time (without a minus mark), instead of the time remaining on the tape (with the minus mark).

NOTE

The AI edit recording function cannot be used with discs containing 31 tracks or more. "TR OVER" is displayed if this is attempted.

PROGRAMMED EDIT RECORDING

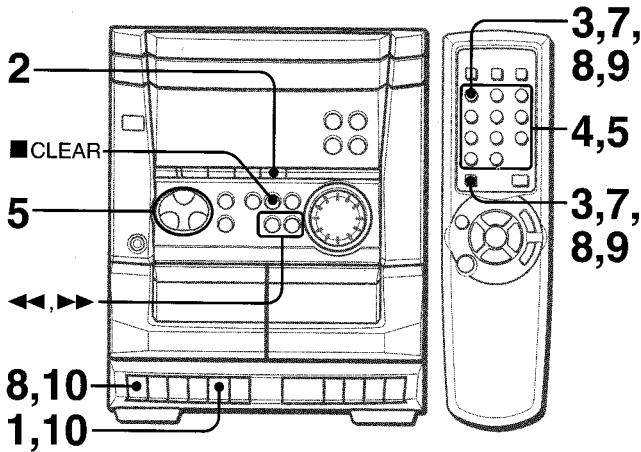

In the programmed edit recording function the tracks can be programmed while checking the remaining time on each side of the tape.

1 Insert the tape into deck 1, and wind up to the beginning of the front side.

Press **■/▲** to open the cassette holder and insert the tape with the side to be recorded on first facing out from the unit. Wind up the tape with **◀◀**.

2 Press CD and load the disc(s).

3 Press CD EDIT/CHECK twice while pressing SHIFT on the remote control.

"EDIT" and "PRGM" are displayed.

- When "AI" is displayed, press **CD EDIT/CHECK** while pressing **SHIFT** again.

4 Press numbered buttons on the remote control to designate the tape length.

10 to 99 minutes can be specified.

- **◀◀** and **▶▶** are also available to designate the tape length.

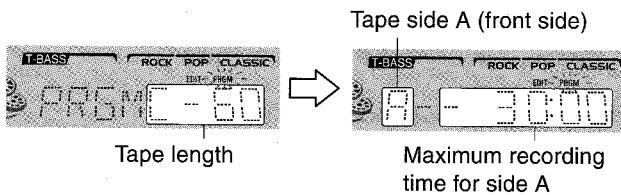

5 Press DISC DIRECT PLAY 1-3 to select a disc. Then, press numbered buttons 0-9 and + 10 on the remote control to program a track.

Example: To select the 10th track of disc 2, press **DISC DIRECT PLAY 2**, then press **+10** and **0**.

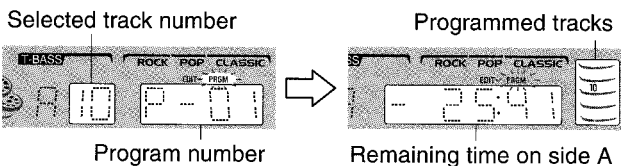

6 Repeat step 5 for the rest of the tracks for side A.

A track whose playing time is longer than the remaining time cannot be programmed.

7 Press CD EDIT/CHECK while pressing SHIFT on the remote control to select side B and program the tracks for side B.

After confirming "B" on the display, repeat step 5.

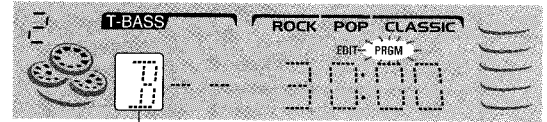

Tape side B (reverse side)

8 Press CD EDIT/CHECK while pressing SHIFT on the remote control to select side A and press ● to start recording.

CD play and recording of edited tracks for the first side start simultaneously. When the end of tape is reached, deck 1 enters the recording stop mode. After entering the recording stop mode, go to step 9.

9 Press CD EDIT/CHECK while pressing SHIFT on the remote control for recording of the second side.

"B" is displayed.

10 Turn over the tape in deck 1 and press ● to start recording.

Recording starts.

To stop recording

Press **■/▲** on deck 1. Recording and CD play stop simultaneously.

To check the order of the programmed track numbers

Before recording, press **CD EDIT/CHECK** while pressing **SHIFT** on the remote control to select side A or B, and press **◀◀** or **▶▶** repeatedly.

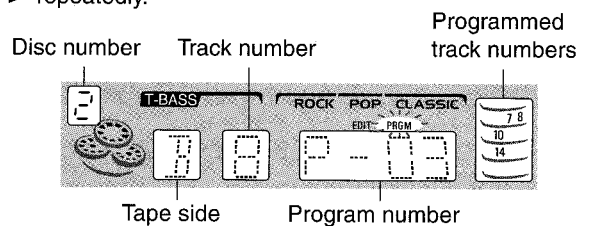

To change the program of each side

Press **CD EDIT/CHECK** while pressing **SHIFT** on the remote control to select side A or B, and press **■ CLEAR** to clear the program on the selected side. Then program tracks again.

To clear the edit program

Press **■ CLEAR** twice so that "EDIT" disappears on the display.

NOTE

- Up to 30 tracks can be programmed from any of the inserted discs.
- "FULL" is displayed if you attempt to program more than 30 tracks.

SETTING THE TIMER

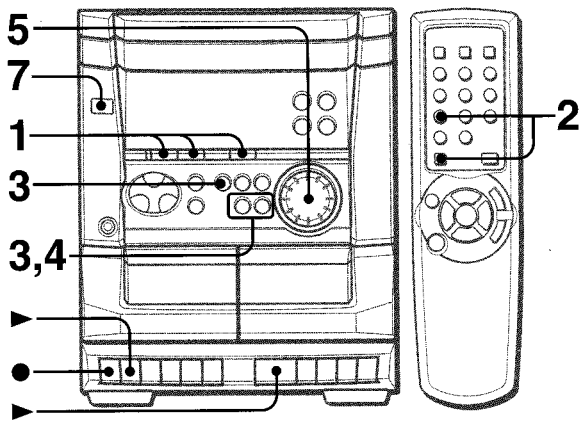

The unit can be turned on at a specified time every day with the built-in timer.

Preparation

Make sure the clock is set correctly.

- 1 Press one of the function buttons to select a source.
- 2 Press **TIMER** while pressing **SHIFT** on the remote control so that ☺ appears on the display. Time and audio source name flash alternately.

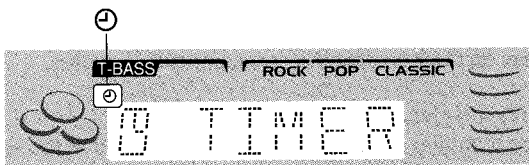

- 3 Within 6 seconds, press ◀ or ▶ to designate the timer-on time, then press ■. Pressing either button changes both the hour and the minute. Holding it down will vary the time rapidly by 10-minute interval, and pressing it repeatedly will vary by 1 minute interval.

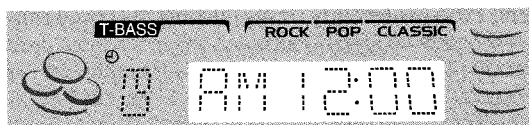

- 4 Within 4 seconds, press ◀ or ▶ to select the duration for the timer-activated period. The duration can be set between 5 and 240 minutes in 5 minute steps.

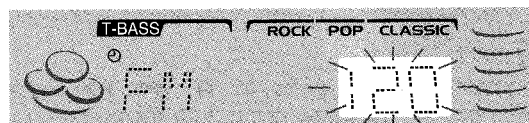

The duration will be automatically set after 4 seconds. It will also be set if ■ is pressed within 4 seconds after step 4.

5 Adjust the volume.

The source sound will play at the volume level set in this step when the power is turned on by the timer. If the volume level is set to 17 or higher, however, it will automatically be set to 16 when the power is turned on.

6 Prepare the source.

To listen to a CD, load the disc to be played first on tray 1. To listen to a tape, insert the tape into deck 1 or 2. To listen to the radio, select the band and tune in to a station.

7 Press POWER to turn off the power.

When the timer-on time is reached, the unit turns on and begins play with the selected source.

8 Get ready for the tape function or the timer recording.

To listen to the tape, press ▶ on deck 1 or 2. To record the source, press ● on deck 1. When the timer-on time is reached, the unit turns on and begins play with the selected source. While the timer is in operation, the display indication is dimmer than usual.

NOTE

You can change the source that was selected in step 1 by pressing one of the function buttons before pressing ■ in step 3.

The timer recording period and tape length

When the length of the tape to be recorded is shorter than the timer recording period, ● on deck 1 is released before the timer is off. When the tape length is longer than the timer recording period, ● is not released. If ● is not released for a long time, the tape in the deck may be damaged. Press ■/▲ to release ●.

To check the timer setting

Press **TIMER** while pressing **SHIFT** on the remote control. The timer-on time, the selected source, and the duration for the timer-activated period will be displayed for 4 seconds.

To change any of the previous setting

Carry out from step 1. However, if you do not change the timer-on time, in step 3 just press ■ twice and continue from step 4.

To cancel the timer standby mode temporarily

Press **TIMER** repeatedly while pressing **SHIFT** on the remote control so that ☺ disappears. To restore the timer standby mode, press again to display ☺.

Using the unit while the timer is set

You can use the unit normally after setting the timer. Before turning off the power, check whether the contents in step 5 and 6 are set as you wish, turn off the power and carry out step 8 if necessary.

NOTE

- Timer playback and timer recording will not begin unless the power is turned off.
- Connected equipment cannot be turned on and off by the built in timer of this unit. Use an external timer.
- If the timer recording is done with the economizing mode (page 6) set to "ECO ON" or "ECO AUTO" and the power turns off, the dimmer mode will be set to "DIMMER 3" and the volume level will be 0 (minimum level) the next time the power is turned on.

SETTING THE SLEEP TIMER

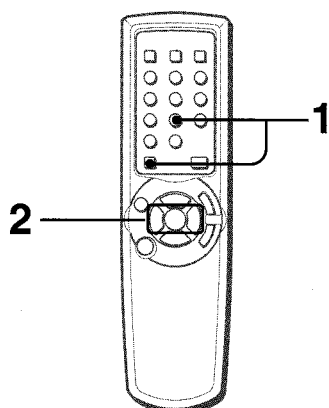

The unit can be turned off automatically at a specified time.

Use the remote control.

1 Press SLEEP while pressing SHIFT.

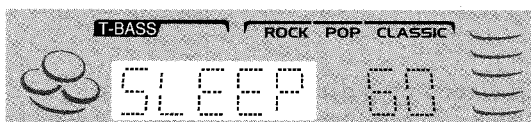

2 Within 4 seconds, press ◀◀ or ▶▶ to specify the time until the power is turned off.

The time changes between 5 and 240 minutes in 5-minute steps.

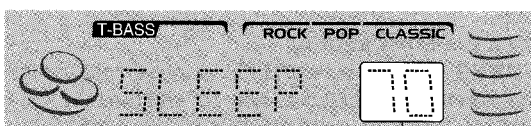

Specified time

While the timer is in operation, the display indication is dimmer than usual.

To check the time remaining until the power is turned off

Press **SLEEP** once while pressing **SHIFT**. The remaining time is displayed for 4 seconds.

To cancel the sleep timer

Press **SLEEP** twice while pressing **SHIFT** so that "SLEEP OFF" appears on the display.

DEMO (Demonstration)

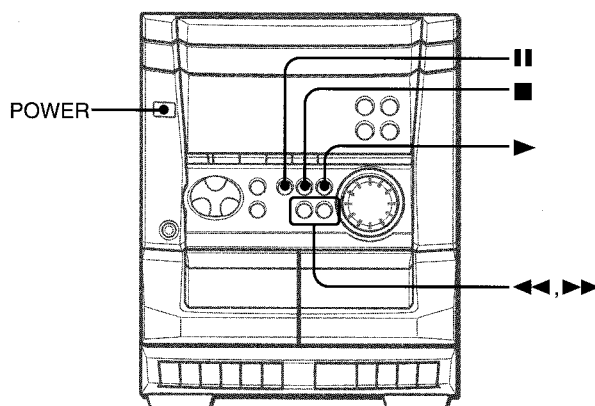

You can enjoy two kinds of DEMO modes on this unit. One is *demo*, the other one is *game demo*.

In the demo mode, colorful illumination demonstrates in the display. In the game demo mode, you can play a game.

To switch the two modes to each other, press POWER while pressing ▶ when the power is off.

To activate the demo or the game demo, press ▶ when the power is off.

To deactivate the demo or the game demo, press II.

To play the game demo

1 To start the game demo, press ▶ when the power is off.

Three numbers on the display start to run.

2 Press ■ once.

The number on the left side stops.

3 Press ■ twice to stop the remaining two numbers.

Scoring:

20 points are given to start the game.

If all the numbers are equal, 50 points are added to the score.

If not equal, one point is subtracted.

If the gained points reach 9999, you win.

If the gained points fall to 0, you lose.

To reset the game demo

Press II, then press ▶. The game starts again.

To change the probability of equalizing the three numbers

Press ◀◀ or ▶▶ repeatedly to select one of the three probability levels when playing the game demo. The tray number indicator in the display changes between 1 and 3. As the tray number increases from 1 to 3, the higher the probability of equalizing.

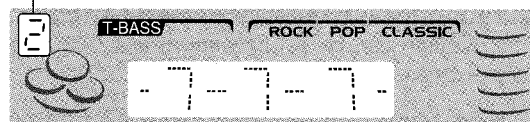
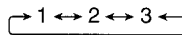

NOTE

- While playing the game demo, II, ■, ◀◀, ▶▶ and ▶ are available only for the game demo. Turn the power on to use these buttons for the functions such as CD playing, etc.
- During the game demo, some indicators unrelated to the actual operation light up on the display.

CONNECTING OPTIONAL EQUIPMENT

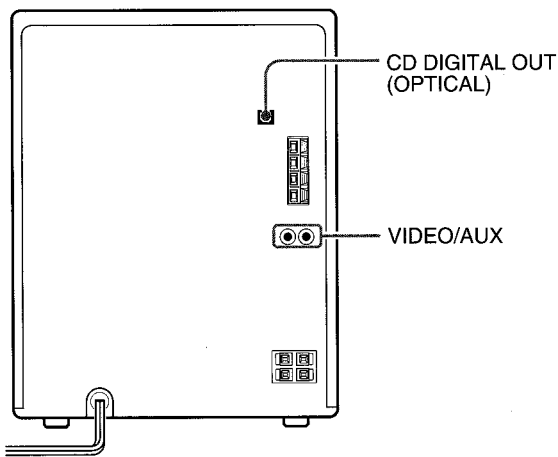

Refer to the operating instructions of the connected equipment for details.

- The connecting cords are not supplied. Obtain the necessary connecting cords.
- Consult your local Aiwa dealer for optional equipment.

VIDEO/AUX JACKS

This unit can input analog sound signals through these jacks. Use a cable with RCA phono plugs to connect audio equipment (turntables, LD players, MD players, VCRs, TV, etc.). Connect the red plug to the **VIDEO/AUX R** jack, and the white plug to the **VIDEO/AUX L** jack.

When connecting a turntable

Use an Aiwa turntable equipped with a built-in equalizer amplifier.

CD DIGITAL OUT (OPTICAL) JACK

This unit can output CD digital sound signals through this jack. Use an optical cable to connect digital audio equipment (DAT deck, MD recorder, etc.).

Remove the dust cap **a** from the **CD DIGITAL OUT (OPTICAL)** jack. Then, connect an optical cable plug to the **CD DIGITAL OUT (OPTICAL)** jack.

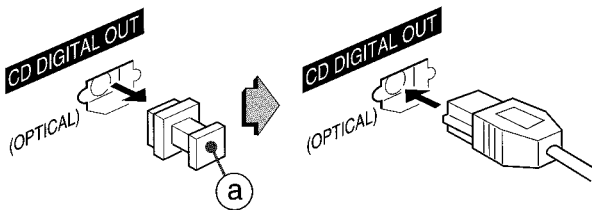

When the CD DIGITAL OUT (OPTICAL) jack is not being used

Attach the supplied dust cap.

LISTENING TO EXTERNAL SOURCES

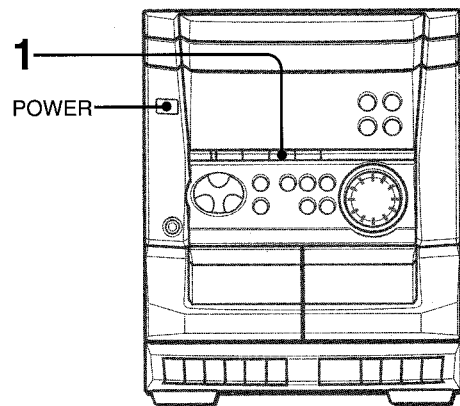

To play equipment connected to the VIDEO/AUX jacks proceed as follows.

1 Press VIDEO/AUX.

"VIDEO" appears on the display.

2 Play the connected equipment.

To change a source name in the display

When **VIDEO/AUX** is pressed, "VIDEO" is displayed initially. It can be changed to "VIDEO", "AUX" or "TV".

With the power on, press **POWER** while pressing **VIDEO/AUX**. Repeat the procedure to select one of the names.

CARE AND MAINTENANCE

Occasional care and maintenance of the unit and the software are needed to optimize the performance of your unit.

To clean the cabinet

Use a soft and dry cloth.

If the surfaces are extremely dirty, use a soft cloth lightly moistened with mild detergent solution. Do not use strong solvents, such as alcohol, benzine or thinner as these could damage the finish of the unit.

To clean the tape heads

When the tape heads are dirty;

- high frequency sound is not emitted
- the sound is not adequately high
- the sound is off-balance
- the tape cannot be erased
- the tape cannot be recorded on

After every 10 hours of use, clean the tape heads with a head cleaning cassette.

Refer to the instructions of the cleaning cassette for details.

To demagnetize the tape heads

The tape heads may become magnetized after long-term use. This may narrow the output range of recorded tapes and increase noise.

After every 20 to 30 hours of use, demagnetize the tape heads with a separately sold demagnetizing cassette.

Refer to the instructions of the demagnetizing cassette for details.

Care of discs

- When a disc becomes dirty, wipe the disc from the center out with a cleaning cloth.

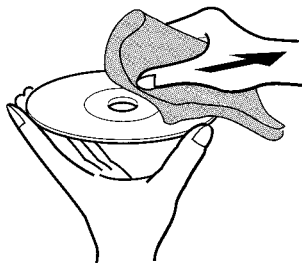

- After playing a disc, store the disc in its case. Do not leave the disc in places that are hot or humid.

Care of tapes

- Store tapes in their cases after use.
- Do not leave tapes near magnets, motors, television sets, or any source of magnetism. This will downgrade the sound quality and cause noise.
- Do not expose tapes to direct sunlight, or leave them in a car parked in direct sunlight.

To reset

If an unusual condition occurs in the display window, reset the unit as follows.

- 1 Press **POWER** to turn off the power.
- 2 Press **POWER** to turn the power back on while pressing **■ CLEAR**. Everything stored in memory after purchase is canceled.

If the power cannot be turned off in step 1 because of a malfunction, reset by disconnecting the AC cord, and connect it again. Then carry out step 2.

TROUBLESHOOTING GUIDE

If the unit fails to perform as described in these Operating Instructions, check the following guide.

GENERAL

There is no sound.

- Is the AC cord connected properly?
- Is there a bad connection? (→ page 4)
- There may be a short circuit in the speaker terminals.
 - Disconnect the AC cord, then correct the speaker connections.

- Was an incorrect function button pressed?

Sound is emitted from one speaker only.

- Is the other speaker disconnected?

An erroneous display or a malfunction occurs.

- Reset the unit as stated below.

The unit blacks out when the power is turned off.

- Is the power economizing mode set to "ECO ON" or "ECO AUTO"? (→ page 6)

The power is not turned on.

- Disconnect the AC cord, and connect it again in a few seconds.

TUNER SECTION

There is constant, wave-like static.

- Is the antenna connected properly? (→ page 4)
- Is the signal weak?
 - Connect an outdoor antenna.

The reception contains noise interferences or the sound is distorted.

- Is the system picking up external noise or multipath distortion?
 - Change the orientation of the antenna.
 - Move the unit away from other electrical appliances.

CASSETTE DECK SECTION

The tape does not run.

- Is the deck in pause mode? (→ page 8)

The sound is off-balance or not adequately high.

- Is the playback head dirty? (→ page 18)

Recording is not possible.

- Is the erasure prevention tab on the tape broken off? (→ page 12)
- Is the recording head dirty? (→ page 18)

Erasure is not possible.

- Is the erasure head dirty? (→ page 18)
- Is a metal tape being used?

High frequency sound is not emitted.

- Is the recording/playback head dirty? (→ page 18)

CD PLAYER SECTION

The CD player does not play.

- Is the disc correctly placed? (→ page 10)
- Is the disc dirty? (→ page 18)
- Is the lens affected by condensation?
 - Wait approximately one hour and try again.

SPECIFICATIONS

Main unit CX-NAJ10

FM tuner section

Tuning range	87.5 MHz to 108 MHz
Usable sensitivity (IHF)	13.2 dBf
Antenna terminals	75 ohms (unbalanced)

AM tuner section

Tuning range	530 kHz to 1710 kHz (10 kHz step) 531 kHz to 1602 kHz (9 kHz step)
Usable sensitivity	350 μ V/m
Antenna	Loop antenna

Amplifier section

Power output	10 W + 10 W (50 Hz – 20 kHz, THD less than 1 %, 6 ohms) 15 W + 15 W (1 kHz, THD less than 10 %, 6 ohms)
Total harmonic distortion	0.1 % (6 W, 1 kHz, 6 ohms, DIN AUDIO)

Inputs

Outputs	VIDEO/AUX: 500 mV SPEAKERS: accept speakers of 6 ohms or more PHONES (stereo jack): accepts headphones of 32 ohms or more
---------	---

Cassette deck section

Track format	4 tracks, 2 channels stereo
Frequency response	50 Hz – 8000 Hz
Recording system	AC bias
Heads	Deck 1: Recording/playback head \times 1, erase head \times 1 Deck 2: Playback head \times 1

Compact disc player section

Laser	Semiconductor laser ($\lambda = 780$ nm)
D/A converter	1 bit dual
Signal-to-noise ratio	85 dB (1 kHz, 0 dB)
Harmonic distortion	0.05 % (1 kHz, 0 dB)

General

Power requirements	120 V AC, 60 Hz
Power consumption	38 W
Power consumption in standby mode	8.0 W with power-economizing mode off 0.9 W with power-economizing mode on

Dimensions (W \times H \times D)	260 \times 324 \times 346 mm (10 $\frac{1}{4}$ \times 12 $\frac{7}{8}$ \times 13 $\frac{5}{8}$ in.)
--------------------------------------	--

Weight	4.8 kg (10 lbs 9 oz)
--------	----------------------

Speaker system SX-NAJ12

Speaker system	2 way, bass reflex (magnetic shielded type)
Speaker units	Woofer: 120 mm (4 $\frac{3}{4}$ in.) cone type Tweeter: 20 ($\frac{13}{16}$ in.) mm ceramic type
Impedance	6 ohms
Sensitivity	86 dB/W/m
Dimensions (W \times H \times D)	220 \times 324 \times 204 mm (8 $\frac{3}{4}$ \times 12 $\frac{7}{8}$ \times 8 $\frac{1}{8}$ in.)
Weight	2.0 kg (4 lbs 7 oz.)

Specifications and external appearance are subject to change without notice.

COPYRIGHT

Please check the laws on copyright relating to recordings from discs, radio or external tape for the country in which the machine is being used.

PARTS INDEX

INDICE DE LAS PARTES

NOMENCLATURE

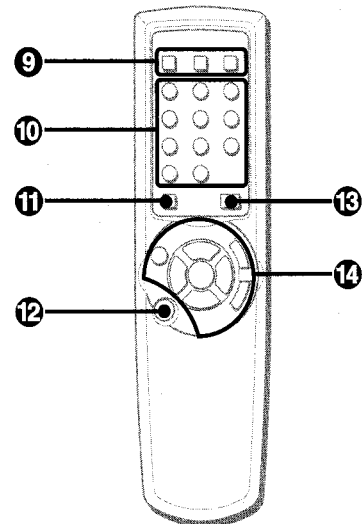
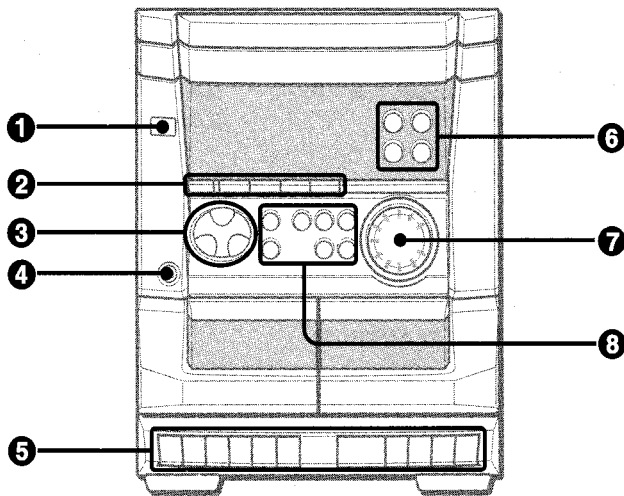

Name/Nombre/Nom	Page/Página/Page
① POWER	6
② ECO	6
TAPE	8
TUNER/BAND	9
VIDEO/AUX	17
CD	10,13,14
③ DISC DIRECT PLAY1-3	10,11,13,14
④ PHONES	8
⑤ ●	12-15
▶	8
◀	8
▶▶	8
■/▲	8,12-15
.....	8,12
⑥ ROCK	8
POP	8
CLASSIC	8
T-BASS	7
⑦ VOLUME	7
⑧ DISC CHANGE	10
▲ OPEN/CLOSE	10
SET	6,7,9,10,15,16
■ CLEAR	7,9-11,13,14,16
▶ PRESET	6,9-11,16
◀◀/◀ DOWN	6,7,9-11,13-16
▶▶/▶ UP	6,7,9-11,13-16

Name/Nombre/Nom	Page/Página/Page
⑨ DISC DIRECT PLAY1-3	10,11,13,14
("4" and "5" are not be used in your system.)	
⑩ 0-9,+10	9-11,13,14
1/CD EDIT/CHECK	10,13,14
2/PRGM	11
3/RANDOM/REPEAT	11
4/GEQ	8
6/T-BASS	7
7/TIMER	15
8/SLEEP	16
9/CLOCK	7
0/MONO TUNER	9
+10/BAND	9
⑪ SHIFT	5
⑫ POWER	6
⑬ FUNCTION	5
⑭ SET	6,7,9,10,15,16
◀◀/◀ DOWN	6,7,9-11,13-16
▶▶/▶ UP	6,7,9-11,13-16
■ CLEAR	7,9-11,13,14,16
▶ PRESET	6,9-11,16
VOL(∧,∨)	7

For assistance and information

call toll free 1-800-BUY-AIWA (United States and Puerto Rico)

AIWA CO.,LTD.